



ID ISC.MRU102-A / ID ISC.MRU102-PoE / ID ISC.MRU102-USB

UHF Mid Range Reader



Note

© Copyright 2016 by
FEIG ELECTRONIC GmbH
Lange Strasse 4
D-35781 Weilburg
Tel.: +49 6471 3109-0
<http://www.feig.de>

With the edition of this document, all previous editions become void. Indications made in this manual may be changed without previous notice.

Copying of this document, and giving it to others and the use or communication of the contents thereof are forbidden without express authority. Offenders are liable to the payment of damages. All rights are reserved in the event of the grant of a patent or the registration of a utility model or design.

Composition of the information in this document has been done to the best of our knowledge. FEIG ELECTRONIC GmbH does not guarantee the correctness and completeness of the details given in this manual and may not be held liable for damages ensuing from incorrect or incomplete information. Since, despite all our efforts, errors may not be completely avoided, we are always grateful for your useful tips.

The instructions given in this manual are based on advantageous boundary conditions. FEIG ELECTRONIC GmbH does not give any guarantee promise for perfect function in cross environments and does not give any guaranty for the functionality of the complete system which incorporates the subject of this document.

FEIG ELECTRONIC call explicit attention that devices which are subject of this document are not designed with components and testing methods for a level of reliability suitable for use in or in connection with surgical implants or as critical components in any life support systems whose failure to perform can reasonably be expected to cause significant injury to a human. To avoid damage, injury, or death, the user or application designer must take reasonably prudent steps to protect against system failures.

Use Exclusion in Transportation Market: Devices which are subject of this document may NOT be sold, used, leased, offer for sale, or otherwise transferred, exported, and imported by anyone in the Transportation Market. "Transportation Market" means (i) Electronic Toll and Traffic Management (ETTM), (ii) Public Sector Vehicle Registration, Inspection and Licensing Programs, (iii) Railroad Locomotive and Wagon tracking, (iv) airport based ground transportation management systems (GTMS) and taxi dispatch, (v) revenue based parking, and (vi) vehicle initiated mobile payment applications, where the RFID sticker/tag is initially attached to the vehicle but not incorporated at the point of vehicle manufacture.

FEIG ELECTRONIC GmbH assumes no responsibility for the use of any information contained in this document and makes no representation that they free of patent infringement. FEIG ELECTRONIC GmbH does not convey any license under its patent rights nor the rights of others.

OBID® and OBID i-scan® are registered trademarks of FEIG ELECTRONIC GmbH.

General information's regarding this document

- The sign "☞" indicates extensions or changes of this manual compared with the former issue.
- If bits within one byte are filled with "-", these bit spaces are reserved for future extensions or for internal testing- and manufacturing-functions. These bit spaces must not be changed, as this may cause faulty operation of the reader.
- The following figure formats are used:
 - 0...9: for decimal figures
 - 0x00...0xFF: for hexadecimal figures,
 - b0...1 for binary figures.
- The hexadecimal value in brackets "[]" marks a control byte (command).

Contents

1. Safety Instructions / Warning - Read before start-up !	6
2. Performance Features of the Reader	7
2.1. Available Reader Types	7
3. Assembly and Wiring	8
3.1. Housed Versions	8
3.2. Viewing and Dimensions	8
3.2.1. Viewing and Dimensions ID ISC.MRU102-POE	8
3.2.2. Viewing and Dimensions ID ISC.MRU102-USB	9
3.2.3. Viewing and Dimensions ID ISC.MRU102-A	9
4. Connections	10
4.1. Power Supply	11
4.1.1. Power Supply via X1	11
4.1.2. Power Supply via Power over Ethernet (PoE)	12
4.2. Power Supply and RS232 Interface on connector X2	13
4.3. USB-Interface on X3 (Host Communication)	14
4.4. Ethernet-Interface on Connector X4 (10/100Tbase)	15
4.5. Antenna Terminal ANT1-3	16
4.6. Internal Antenna ANT4	16
5. Control and Display Elements	17
5.1. LED	17
6. Technical Data	18
7. Radio Approvals	20
7.1. Europe (CE)	20

7.2. Declaration of Conformity	20
7.3. USA (FCC) and Canada (IC)	21
7.3.1. USA (FCC) and Canada (IC) warning notices	21
7.3.2. Label Information Reader Module ID ISC.MRU102-A / -PoE / -USB	22
7.3.3. Installation with FCC / IC Approval.....	22
7.3.4. USA (FCC) and Canada (IC) approved antennas	22

ANNEX	23
ANNEX A - Accessories	23
ANNEX B – Wall Mounting Kit ID ISC.MS.MR/PR-A	25
ANNEX C – Serial data cable ID CAB.RS-A	26

1. Safety Instructions / Warning - Read before start-up !

- The device may only be used for the intended purpose designed by for the manufacturer.
- The operation manual should be conveniently kept available at all times for each user.
- Unauthorized changes and the use of spare parts and additional devices which have not been sold or recommended by the manufacturer may cause fire, electric shocks or injuries. Such unauthorized measures shall exclude any liability by the manufacturer.
- The liability-prescriptions of the manufacturer in the issue valid at the time of purchase are valid for the device. The manufacturer shall not be held legally responsible for inaccuracies, errors, or omissions in the manual or automatically set parameters for a device or for an incorrect application of a device.
- Repairs may only be executed by the manufacturer.
- Installation, operation, and maintenance procedures should only be carried out by qualified personnel.
- Use of the device and its installation must be in accordance with national legal requirements and local electrical codes .
- When working on devices the valid safety regulations must be observed.
- Special advice for carriers of cardiac pacemakers:
Although this device doesn't exceed the valid limits for electromagnetic fields you should keep a minimum distance of 25 cm between the device and your cardiac pacemaker and not stay in an immediate proximity of the device respective the antenna for some time.

2. Performance Features of the Reader

The Reader ID ISC.MRU102 is designed for reading of passive data carriers, so-called „Smart Labels“ at an operating frequency in the UHF band between 860 MHz and 960 MHz. Transponders according to EPC Class1 Gen2 are supported. Optional an Upgrade Code for the reading of ISO 18000-6-C transponders is available. The reader is designed for application with small tag population.

The reader is equipped with 3 SMA connectors for conduction of an external antennas (ANT1 – ANT3). Additional an integrated antenna (ANT4) is available.

The reader is designed for use in applications with small tag populations. The reader is available in three different versions. Depending on the used version a connection to the Host-System can either be made via the serial RS232, the USB or the Ethernet Interface.

2.1. Available Reader Types

The following reader types are currently available:

Table 1: Ordering Information – Reader

Model	Description	Order Number
ID ISC.MRMU102-A	Module version with asynchronous RS232- and USB- Interface, 3 x SMA connectors for external antennas , 50Ohm 1 x integrated antenna	3779.000.00
ID ISC.MRU102-A	Housed version with asynchronous RS232- Interface, 3 x SMA connectors for external antennas , 50Ohm 1 x integrated antenna	4495.000.00
ID ISC.MRU102-POE	Housed version with Ethernet- Interface, Power over Ethernet 3 x SMA connectors for external antennas , 50Ohm 1 x integrated antenna	4492.000.00
ID ISC.MRU102-USB	Housed version with USB- Interface, 3 x SMA connectors for external antennas , 50Ohm 1 x integrated antenna	4494.000.00
ID ISC.MRU102-POE-LED	Housed version with Ethernet- Interface, Power over Ethernet 1 x integrated antenna 3 x optical and 1 x acoustic signaler	3888.000.00

3. Assembly and Wiring

3.1. Housed Versions

The Reader is designed for indoor use. It can be wall-mounted, in this case the wall-mount kit should be ordered separately. (see Appendix: ANNEX B – Wall Mounting Kit ID ISC.MS.MR/PR-A)

NOTE:

Before any installation the intended position of the reader should be tested for its suitability.

3.2. Viewing and Dimensions

3.2.1. Viewing and Dimensions ID ISC.MRU102-POE

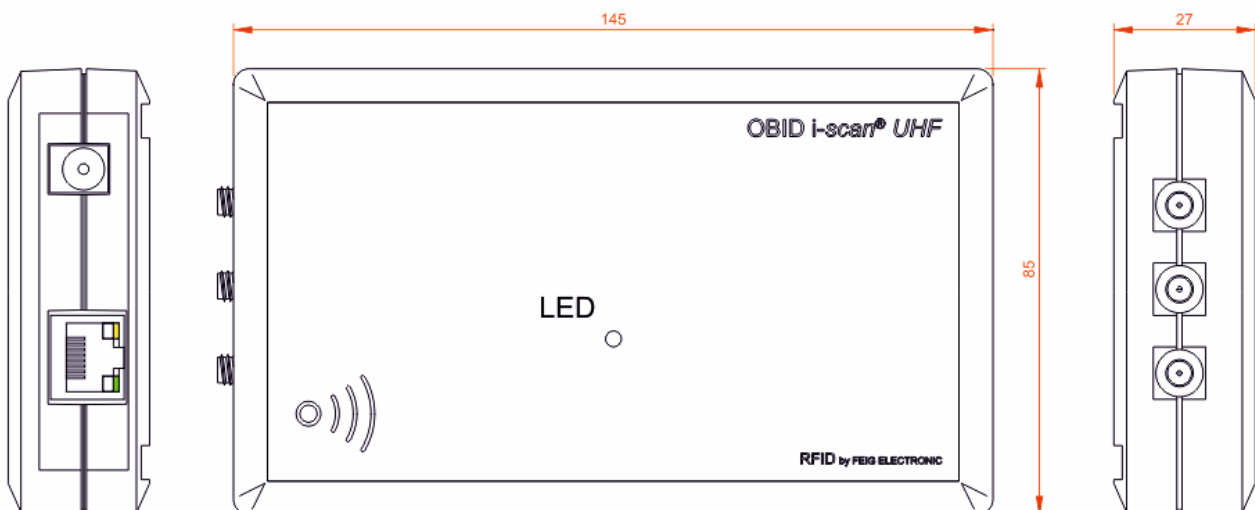

Figure 1: Viewing and Dimensions ID ISC.MRU102-POE (all dimensions in mm)

3.2.2. Viewing and Dimensions ID ISC.MRU102-USB

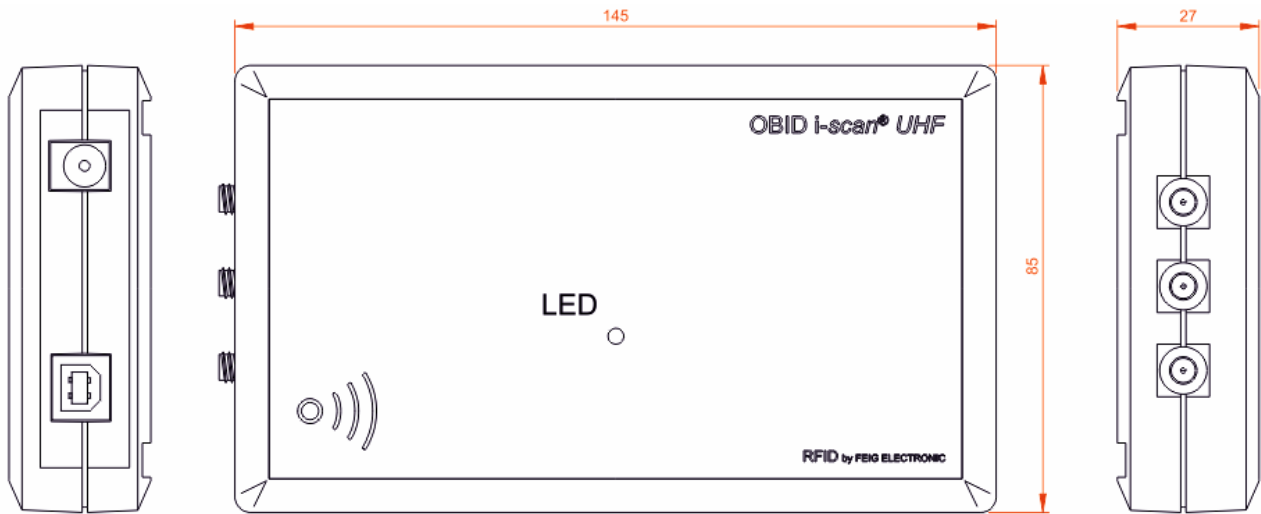

Figure 2: Viewing and Dimensions ID ISC.MRU102-USB (all dimensions in mm)

3.2.3. Viewing and Dimensions ID ISC.MRU102-A

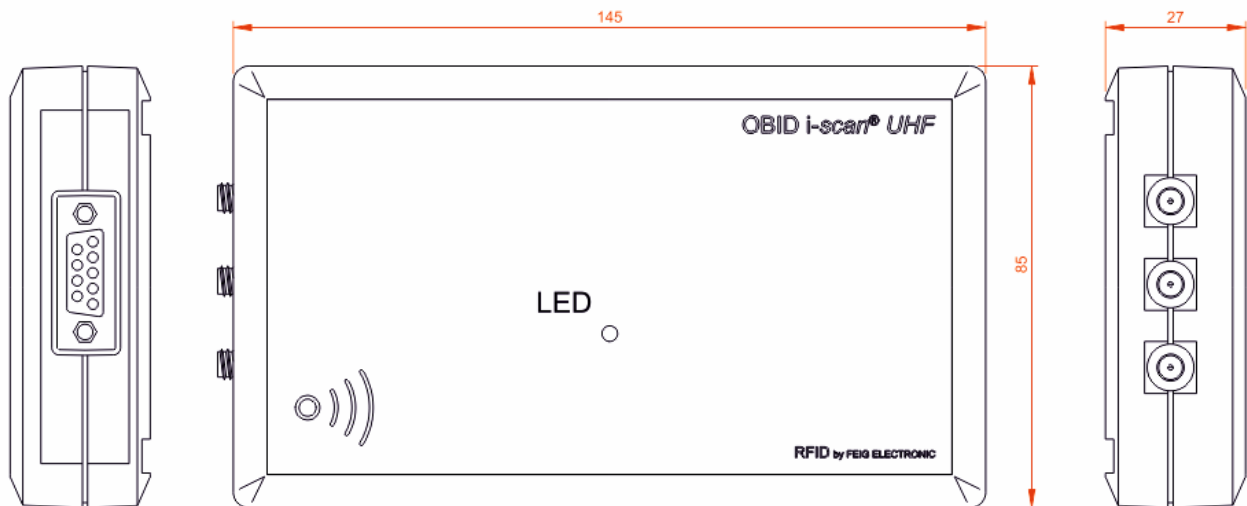

Figure 3: Viewing and Dimensions ID ISC.MRU102-A (all dimensions in mm)

4. Connections

Depending on the reader variant different connectors are available. Figure 4: Connection overview displays the arrangement and the Table 2: Connectors shows which connector can be used for the different interface cable.

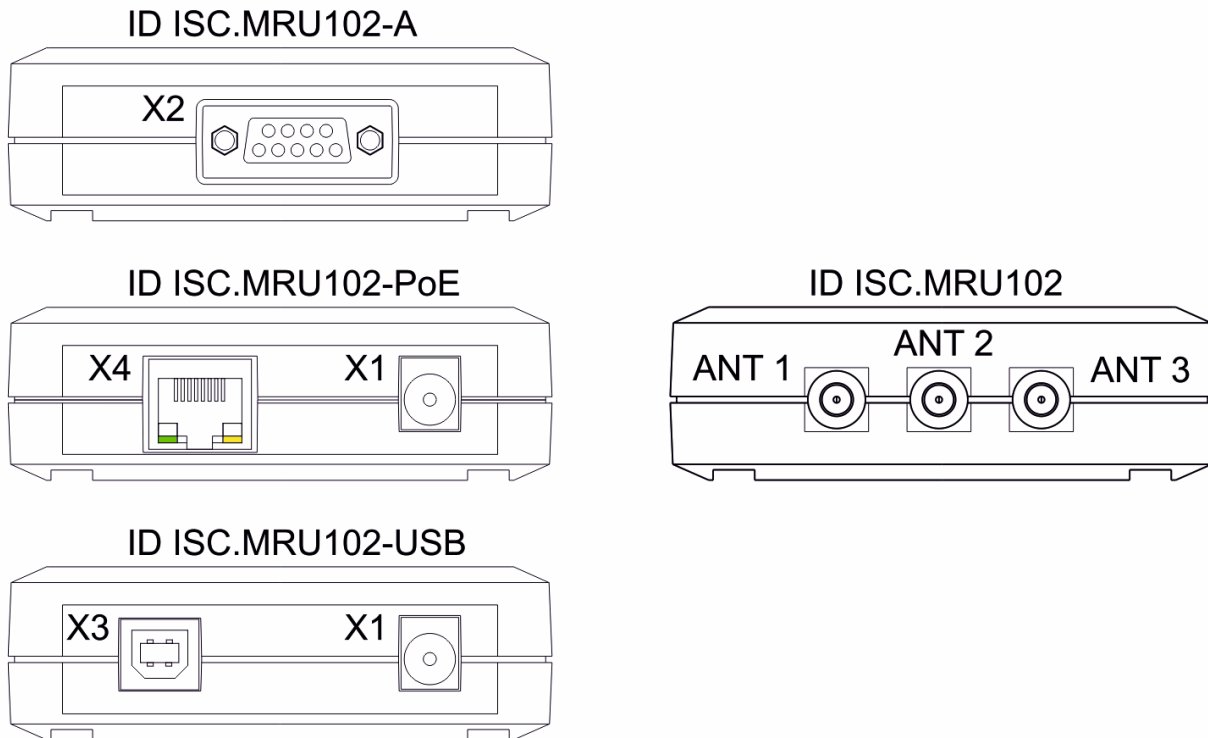

Figure 4: Connection overview

Table 2: Connectors

Connector	Description
ANT 1-3	4.5. Antenna Terminal ANT1-3
ANT 4	4.6. Internal Antenna ANT4
X1	4.1.1. Power Supply via X1
X2	4.2. Power Supply and RS232 Interface on connector X2
X3	4.3. USB-Interface on X3 (Host Communication)
X4	4.4. Ethernet-Interface on Connector X4 (10/100Tbase)

4.1. Power Supply

4.1.1. Power Supply via X1

Connect the 12 V DC to 24 V DC supply voltage to socket X1 on the circuit board.

Table 3: Connecting the supply voltage

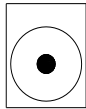
Terminal	Name	Description	X 1
X1 / inside	Vcc	Vcc – supply voltage (+)	
X1 / outside	GND	Ground – supply voltage (-)	

CAUTION:

The reader has to be supplied by a limited power supply (e.g. NEC Class 2/LPS power supply) according IEC EN 60950-1 chapter 2.5, only.

Reversing the polarity of the supply voltage may destroy the device.

Each reader has to be supplied by a separate external power supply.

Power supply recommendations:

To take full advantage of the Reader performance, you must use a sufficiently regulated and low-noise power supply. When using a switching power supply, be sure that its internal switching frequency is less than 300 kHz. (See also:ANNEX A - Accessories)

Table 4: Recommended power supply

Part No.	Description.	Feig Article No
ID NET.12V-B-EU	Power Supply 95 - 265V AC Input Voltage, with angular DC Plug 2,5mm*5,5mm Output: 12 V DC/---; 700mA Ambient Operating Temperature: 0°C to +40°C	1688.002.00
ID NET.12V-B-GB		3886.000.00
ID NET.12V-B-US		3887.000.00

NOTE:

The power supply is supplied with a DC/--- plug 2.5mm x 5.5mm. This is compatible with the readers socket X1.

4.1.2. Power Supply via Power over Ethernet (PoE)

Optional the reader (only MRU102-PoE) can be powered via the LAN connector on X4 with the use of a PoE „Power over Ethernet“ power supply according to IEEE802.3af*, Class2 (6,49 Watt). The DC supply can be achieved via the free pin’s 4,5 and 7,8 (Midspan-Power). Also a “Phantom Powering” (Inline-Power) via the signal pin’s 1,2,3,and 6 is possible.

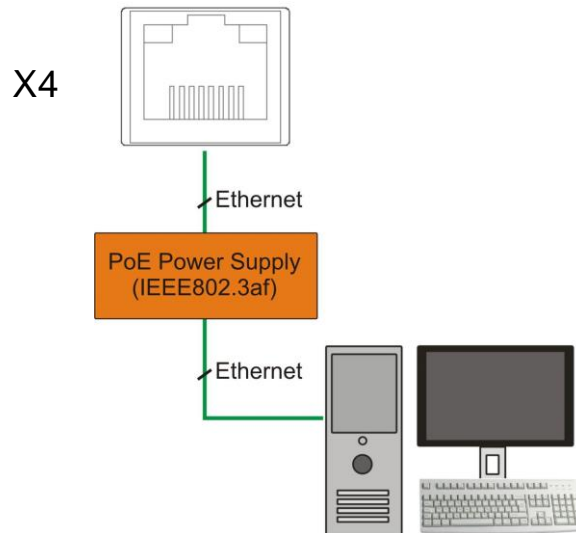

Figure 5: LAN and PoE connection

NOTE:

The reader has to be supplied by a limited power supply (e.g. NEC Class 2/LPS power supply) according IEC EN 60950-1 chapter 2.5, only.

It must be ensured that the reader is supplied with 42,5 V DC (48 V DC – cable losses) at least.

The maximum cable distance for Ethernet is 100m.

It is recommended to use a shielded twisted pair STP CAT5 cable.

* For detailed technical information regarding the 802.3af standard, please refer to the most recent edition of the corresponding IEEE specification.

PoE - power supply recommendations:

Table 5: Recommended PoE Power Supply

Article No.	Name	Description
3842.000.00	ID NET.PoEI13W-A	Power over Ethernet Supply 100-240V AC (Continental European Plug), Output: 48V DC/---; 0,5A

4.2. Power Supply and RS232 Interface on connector X2

For the power supply connection and the connection of the asynchronous interface RS232 the reader provides a 9-pin D-Subminiature female connector.

Table 6: Connection assignment of the connector X2

X2	Interface + Power supply
2	TxD / B-
3	RxD / A+
5	GND
7	GND
9	Vcc
1;4;6;8	n.c.

For this reader a serial cable with integrated DC connector is available.
(See: ANNEX C – Serial data cable ID CAB.RS-A).

Table 7: Serial data cable

Feig Part No.	Description
1690.000.00	ID CAB.RS-A

NOTE:

The Interface parameter can be configured via software protocol (e.g. ISOStart). Further details must be taken from the system manual of the reader H10410-Xe-ID-B.pdf

4.3. USB-Interface on X3 (Host Communication)

There is a USB-socket X3 on board for the connection of the USB-Interface. The pinout is standardized. The data rate is reduced to 12 Mbit (USB full speed). A standard USB-cable can be used.

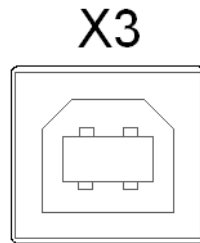

Figure 6: USB interface for host communication

NOTE:

The length of the USB-cable can be a max. of 5 meter. It isn't allowed to use longer cables!

The reader must be powered with a external power supply even if it is connected to a "high powered port".

4.4. Ethernet-Interface on Connector X4 (10/100Tbase)

The Reader has an integrated 10 / 100 base-T network port for an RJ-45. Connection is made on X4 and has an automatic “Crossover Detection” according to the 100BASE-T Standard.

With structured cabling CAT 5 cables should be used. This ensures a reliable operation at 10 Mbps or 100 Mbps.

The prerequisite for using TCP/IP protocol is that each device has a unique address on the network. All Readers have a factory set IP address. Interface parameter can be configured via software protocol (e.g. ISOStart).

Table 8: Standard factory configuration of the Ethernet connection

Network	Address
IP-Address	192.168.10.10
Subnet-Mask	255.255.0.0
Port	10001
DHCP	OFF

NOTE:

The reader provides a DHCP able TCP/IP interface.

It is recommended to use a shielded twisted pair STP CAT5 cable.

4.5. Antenna Terminal ANT1-3

Three SMA sockets (ANT1 – ANT3) are provided on the circuit board for connection of external antennas. The maximum tightening torque for the SMA socket is 0.45 Nm.

CAUTION:

Higher tightening torque will damage the connector.

Table 9: Connecting the external antenna

Terminal	Description
ANT1-3	Connecting the external antenna (input impedance 50Ω)

NOTE:

When connecting an antenna, ensure that it does not exceed the permissible limits prescribed by the national regulations for radio frequency devices.

4.6. Internal Antenna ANT4

Additionally the reader is equipped with an internal antenna (ANT4). The internal antenna supports far field transponders as well as near field transponders. The internal antenna is located in the bottom left corner of the housing and is marked with an antenna symbol. The maximum read range of the antenna in combination with a far field transponder is approx. 40 cm. In combination with a near field transponder the maximum read range is approx. 5 cm.



Figure 7: Position of the internal antenna

5. Control and Display Elements

5.1. LED

The Reader's LED can be configured through software.

The following table shows the default setting.

Table 10: Default configuration of the LEDs

Abbreviation	Description
LED green	"RUN " - Turns on when the Reader is ready
LED red	„LABEL“ - Turns on when a transponder is detected. - Flashes if RF-Warning (red – green alternating with 8Hz) (Temperature alarm, short circuit on antenna output)

6. Technical Data

MECHANICAL DATA

Housing	Plastic ABS
Dimension (W x H x D)	145 mm x 85 mm x 27 mm
Weight	200 g
Protection Class	IP 30
Color	similar to RAL 9018 (Papyrus white)

ELECTRICAL DATA

Power Supply

- | | |
|---------------------|---------------------------|
| • ID ISC.MRU102-A | 12 V DC to 24 V DC |
| • ID ISC.MRU102-USB | 12 V DC to 24 V DC |
| • ID ISC.MRU102-PoE | 12 V DC to 24 V DC or PoE |

Power Consumption	max. 7 W
-------------------	----------

Operating Frequency	860 MHz to 960 MHz
---------------------	--------------------

RF-Power	max. 500 mW ± 1,5 dB
----------	----------------------

Antenna Connector	3 x SMA female(50 Ω) 1 x integrated Antenna (ANT4)
-------------------	---

Interfaces

- | | |
|---------------------|-------------------|
| • ID ISC.MRU102-A | RS232 |
| • ID ISC.MRU102-USB | USB (Full Speed) |
| • ID ISC.MRU102-PoE | Ethernet (TCP/IP) |

FUNCTIONAL PROPERTIES

Protocol Modes	FEIG ISO HOST (Advanced Protocol Frame) Buffered Read Mode Scan Mode (MRU102-USB, MRU102-A) Notification Mode (MRU102-PoE)
Supported Transponder Types	EPC Class 1 Generation 2 ISO 18000-6-C (Upgrade Code required)
Signaler	1 LED (multi-color red and green)
Further Features	Anti-collision RSSI Temperature Monitoring*

AMBIENT CONDITIONS

Temperature Range	
• Operation	-25 °C to +55 °C (-USB) -25 °C to +45 °C (-PoE)
• Storage	-25 °C to +85 °C
Humidity	5 % to 95 % non-condensing

APPLICABLE STANDARDS

Radio Regulation	
• Europe	EN 302 208
• USA	FCC 47 CFR Part 15
• Canada	IC RSS-Gen, RSS-210
EMC	EN 301 489
Vibration	EN 60068-2-6 10 Hz to 150 Hz: 0,075 mm / 1 g
Shock	EN 60068-2-27 Acceleration 30 g

* Caution: Overheating of the device may result in performance losses. It is recommended to activate the RF of the reader only if there is a transponder in the detection range of an antenna.

7. Radio Approvals

7.1. Europe (CE)

When used according to regulation, this radio equipment conforms with the basic requirements of Article 3 and the other relevant provisions of the R&TTE Guideline 1999/E6 dated March 99.



Performance Classification according to ETSI EN 301 489: Class 2

7.2. Declaration of Conformity

Hereby, FEIG ELECTRONIC GmbH declares that the radio equipment type ID ISC.MRU102 is in compliance with Directive 2014/53/EU.

The full text of the EU declaration of conformity is available at the following internet address:
www.feig.de.

7.3. USA (FCC) and Canada (IC)

7.3.1. USA (FCC) and Canada (IC) warning notices

Product name:	ID ISC.MRU102-A ID ISC.MRU102-PoE ID ISC.MRU102-USB
Reader name:	ID ISC.MRU102-A ID ISC.MRU102-PoE ID ISC.MRU102-USB
FCC ID: IC:	PJMMRU102 6633A-MRU102
Notice for USA and Canada	<p>This device complies with Part 15 of the FCC Rules and with RSS-210 of Industry Canada.</p> <p>Operation is subject to the following two conditions.</p> <p>(1) this device may not cause harmful interference, and</p> <p>(2) this device must accept any interference received, including interference that may cause undesired operation.</p> <p>Unauthorized modifications may void the authority granted under Federal communications Commission Rules permitting the operation of this device.</p> <p>This equipment has been tested and found to comply with the limits for a Class A digital device, pursuant to Part 15 of the FCC Rules. These limits are designed to provide reasonable protection against harmful interference when the equipment is operated in a commercial environment. This equipment generates, uses, and can radiate radio frequency energy and, if not installed and used in accordance with the instruction manual, may cause harmful interference to radio communications. Operation of this equipment in a residential area is likely to cause harmful interference in which case the user will be required to correct the interference at his own expense.</p> <p>Le présent appareil est conforme aux CNR d'Industrie Canada applicables aux appareils radio exempts de licence. L'exploitation est autorisée aux deux conditions suivantes :</p> <p>(1) l'appareil ne doit pas produire de brouillage, et</p> <p>(2) l'utilisateur de l'appareil doit accepter tout brouillage radioélectrique subi, même si le brouillage est susceptible d'en compromettre le fonctionnement.</p>

Warning: Changes or modification made to this equipment not expressly approved by FEIG ELECTRONIC GmbH may void the FCC authorization to operate this equipment.

7.3.2. Label Information Reader Module ID ISC.MRU102-A / -PoE / -USB

The following information must be placed at the outer side of the housing in which the reader is mounted.

<p>Contains FCC ID PJMMRU102 Contains IC: 6633A-MRU102</p>
--

7.3.3. Installation with FCC / IC Approval

FCC-/IC-NOTICE: To comply with FCC Part 15 Rules in the United States / with IC Radio Standards in Canada, the system must be professionally installed to ensure compliance with the Part 15 certification / IC certification. It is the responsibility of the operator and professional installer to ensure that only certified systems are deployed in the United States / Canada.

7.3.4. USA (FCC) and Canada (IC) approved antennas

This radio transmitter (identify the device by certification number, or model number if Category II) has been approved by Industry Canada to operate with the antenna types listed below with maximum permission gain and required antenna impedance for each antenna type indicated. Antenna types, not included in this list, having a gain greater than the maximum gain indicated for that type, are strictly prohibited for use with this device

Le présent émetteur radio (identifier le dispositif par son numéro de certification ou son numéro de modèle s'il fait partie du matériel de catégorie I) a été approuvé par Industrie Canada pour fonctionner avec les types d'antenne énoncé ci-dessus et ayant un gain admissible maximal et l'impédance requise pour chaque type d'antenne. Les types d'antenne non inclus dans cette liste, ou dont le gain est supérieur au gain maximal indiqué, sont strictement interdits pour l'exploitation de l'émetteur

Following antennas are approved by FCC according FCC Part 15 and IC Canada according RS210

- ID ISC.ANT.U170/170 –FCC (4.0 dBic)
- ID ISC.ANT.U270/270-FCC (9.0 dBic)
- ID ISC.ANT.U600/270-FCC (10,5 dBic)
- Integrated antenna (- 7dBic)

ANNEX**ANNEX A - Accessories**

The following accessories are available for the Reader.

Table 11: Accessories

Article No.	Part No.	Description
1686.000.00	ID CAB.USB-A	USB-cable 2,5m
1690.000.00	ID CAB.RS-A	Serial data cable
1688.002.00	ID NET.12V-B-EU	Power Supply 95 - 265V AC Input Voltage, (Continental European Plug), with angular DC Plug 2,5mm*5,5mm Output: 12 V DC/---; 700mA Ambient Operating Temperature: 0°C to +40°C
3886.000.00	ID NET.12V-B-GB	Power Supply 95 - 265V AC Input Voltage, (GB/UK Plug), with angular DC Plug 2,5mm*5,5mm Output: 12 V DC/---; 700mA Ambient Operating Temperature: 0°C to +40°C
3887.000.00	ID NET.12V-B-US	Power Supply 95 - 265V AC Input Voltage, (US Plug), with angular DC Plug 2,5mm*5,5mm Output: 12 V DC/---; 700mA Ambient Operating Temperature: 0°C to +40°C
3842.000.00	ID NET.PoE113W-A	Power over Ethernet Supply 100-240V AC (Continental European Plug), Output: 48V DC/---; 0,5A
EU: 3198.000.00 FCC: 3685.000.00	ID ISC.ANT.U600/270 UHF Antenna	powerful UHF Antenna with 3dB beamwidth of 30° x 65°
EU: 3199.000.00 FCC: 3686.000.00	ID ISC.ANT.U270/270 UHF Antenna	powerful UHF Antenna with 3dB beamwidth of 65° x 65°
EU: 3200.000.00 FCC: 3687.000.00	ID ISC.ANT.U170/170 UHF Antenna	Flat, compact UHF Antenna with 3dB beamwidth of 85° x 85°
3308.000.00	ID ISC.ANT.U600/270-MS Mounting Set Antenna UHF	Pole mounting set for antenna ID ISC.ANT.U600/270, diameter up to 60 mm
3309.000.00	ID ISC.ANT.U270/270-MS Mounting Set Antenna UHF	Pole mounting set for antenna ID ISC.ANT.U270/270, diameter up to 60 mm
3310.000.00	ID ISC.ANT.U170/170-MS Mounting Set Antenna UHF	Pole mounting set for antenna ID ISC.ANT.U170/170, diameter up to 60 mm

1654.002.00	ID ISC.ANT.C2-A UHF Antenna Cable 2m	Antenna cable, length: 2 m
1654.003.00	ID ISC.ANT.C6-A UHF Antenna Cable 6m	Antenna cable, length: 6 m

ANNEX B – Wall Mounting Kit ID ISC.MS.MR/PR-A

The wall mounting kit can be used to attach the Reader to a flat surface.

- Remove the screws from the back side of the Reader.
- Attach the individual wall hangers using the screws supplied with the mounting kit.

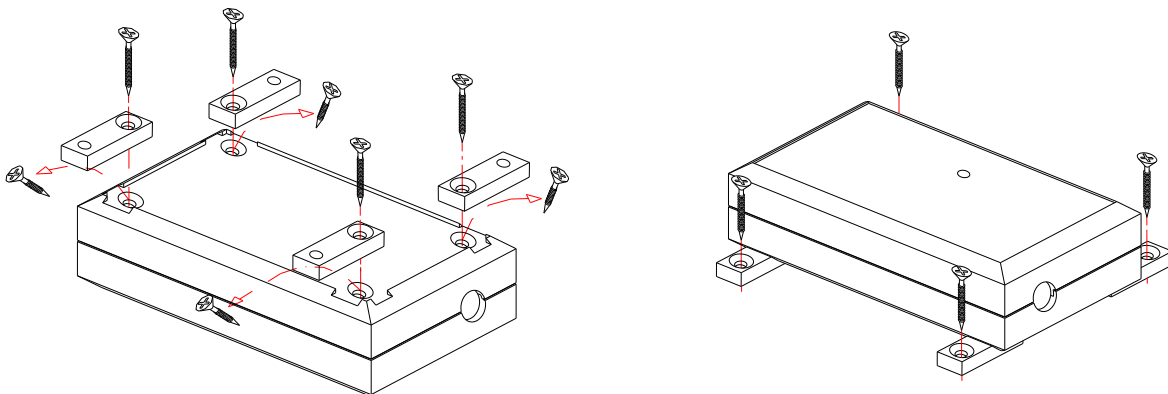

Figure 8: Mounting wall hangers

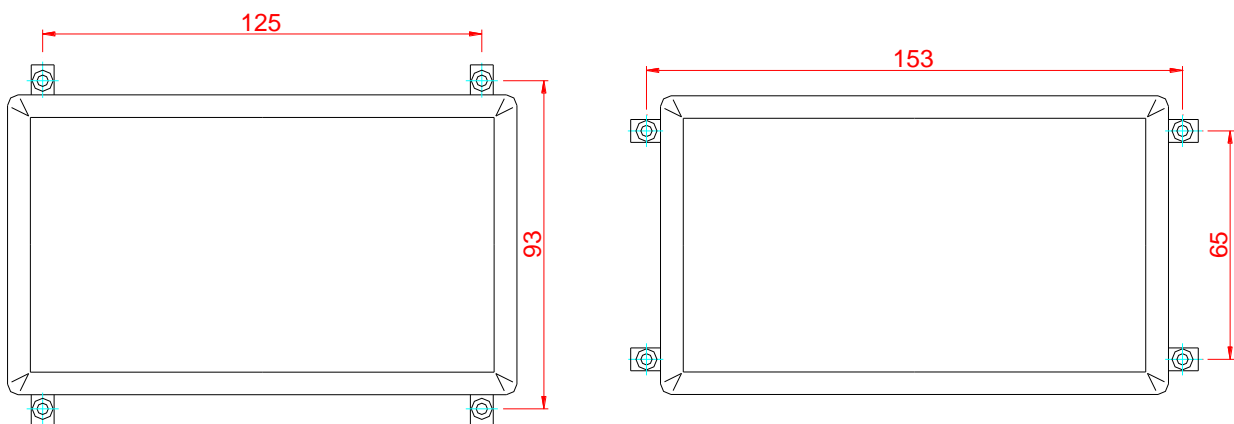

Figure 9: Mounting drill dimensioning (all dimensions in mm)

ANNEX C – Serial data cable ID CAB.RS-A

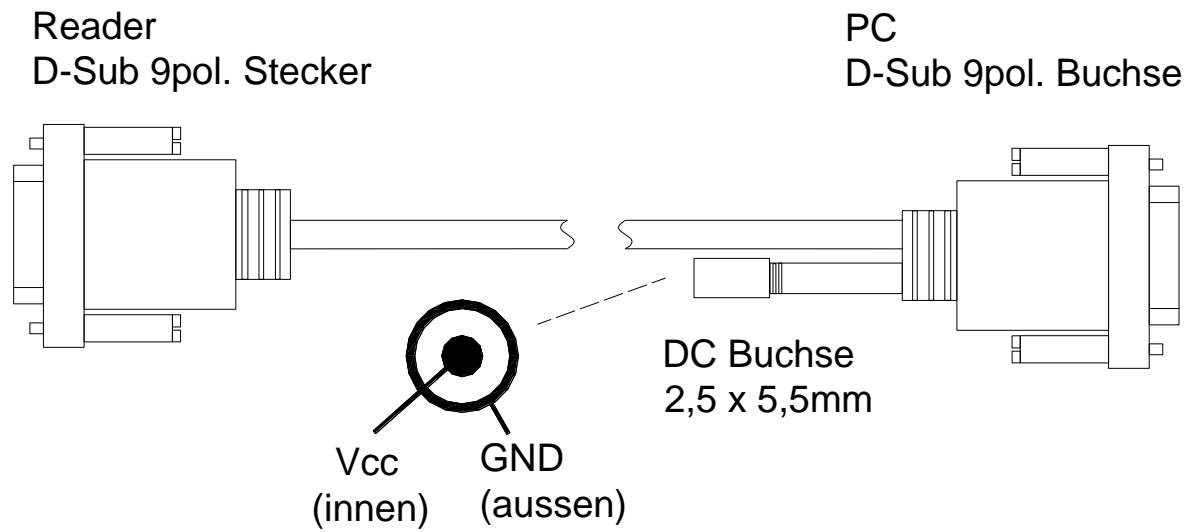

Figure 10: Serial data cable with connector for power supply